



National Kaohsiung  
CENTER FOR THE ARTS

WEI WU YINGGE

衛武營 國家藝術文化中心

國家表演藝術中心 National Performing Arts Center

## CONCERT HALL

### Technical Information



# Table of Contents

<b>0 General Information</b>	<b>1</b>
0-1 National Kaohsiung Center for the Arts (WEIWUYING)	1
0-2 Concert Hall	1
0-3 Traffic Information	2
0-4 Contact Information	2
0-5 Stage door	2
0-6 Auditorium / Seating	3
0-7 Concert Hall Plan	5
0-8 Concert Hall Section	7
<b>1 Stage</b>	<b>8</b>
1-1 Stage	8
1-2 Hoisting	8
1-3 Stage Elevation Platform	9
1-4 Acoustic Panel	9
<b>2 Lighting</b>	<b>10</b>
2-1 Lighting System	10
2-2 Lighting Instrument	11
2-3 Accessories	12
2-4 Lighting Circuit	15
2-5 Portable Lift	19
2-6 Additional Power Supply	19
2-7 Working Light / Auditorium Light / Blackout	19
<b>3 Audio/Video Systems</b>	<b>20</b>
3-1 Audio Facilities	20
3-2 Control Room	20
3-3 Stage Manager' s Console	20
3-4 Machine Room	20
3-5 Microphone	21
3-6 Communications	21
3-7 Locations of Communications	22
3-8 Stage Cameras and Video Surveillance Systems	22
3-9 Paging Systems	22
3-10 Projector	23
<b>4 Backstage</b>	<b>24</b>
4-1 Dressing Room and Green Room	24
4-2 Orchestra Facilities	24
4-3 Pianos (shared between four <i>venues</i> )	25
4-4 Pipe Organ	26
4-5 Loading Dock/ Scenery Shipping Path / Loading Flow	27
4-6 Other Facilities	29

Last updated:2022/1/28

## 0 General Information

### 0-1 National Kaohsiung Center for the Arts (WEIWUYING)

CENTER FOR THE ARTS, ARTS FOR THE PEOPLE, National Kaohsiung Center for the Arts will become one of the important theatre complexes of the international art field. It includes four performance blocks, the 2,236 seat Opera House, the 1981 seat Concert Hall, the 1210 seat Play House and the 434 seat Recital Hall.



### 0-2 Concert Hall

The Concert Hall features a unique vineyard style. The unique design allows audience at various heights to enjoy the same optimal acoustic and visual effects, taking care of each and every member in the audience. The seating arrangement encircles the stage, bringing the audience closer to the stage for more intimate experiences with conductors and performers.



### 0-3 Traffic Information

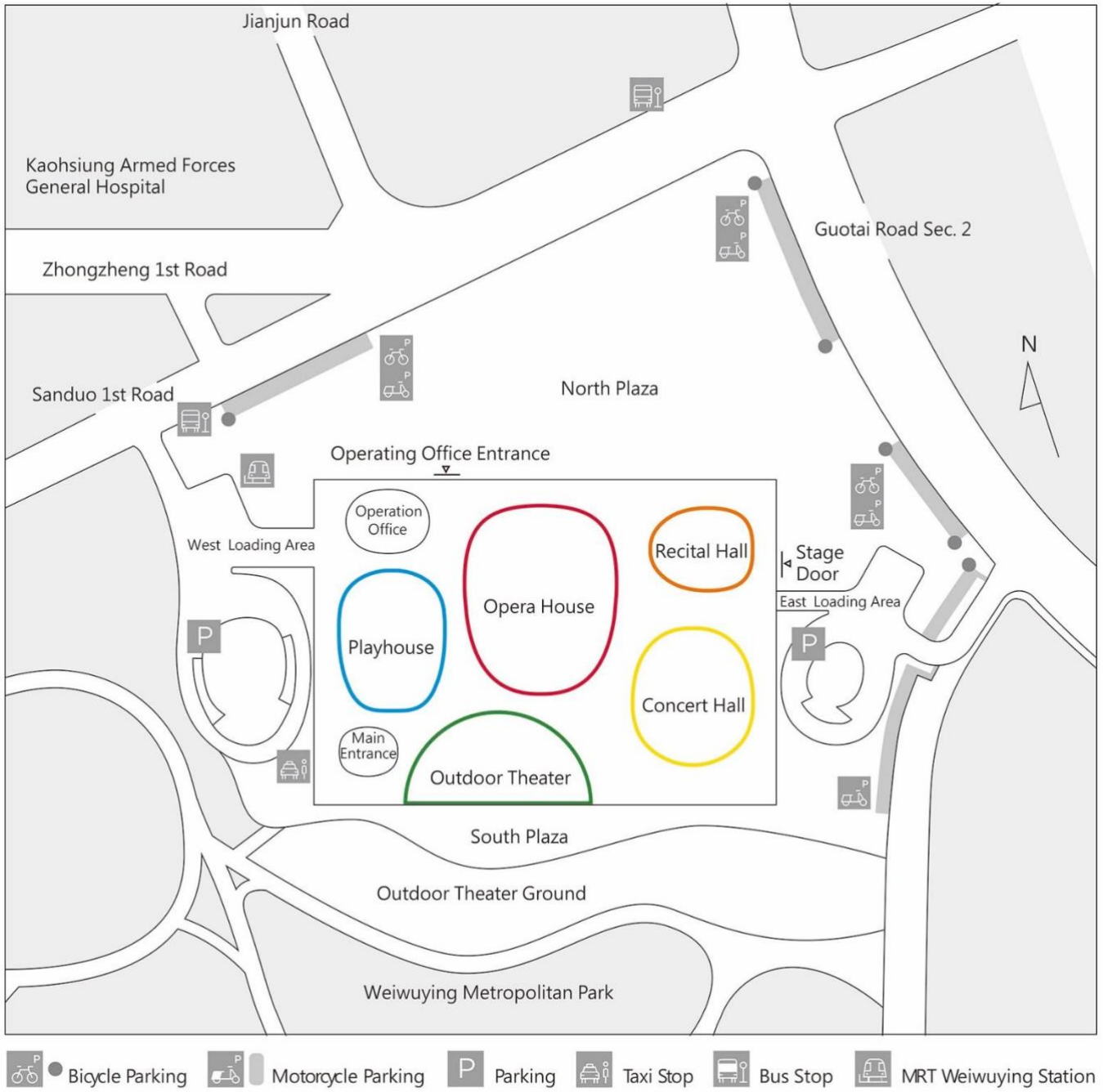

### 0-4 Contact Information

#### National Kaohsiung Center for the Arts (Weiwuying)

No.1, Sanduo 1st Rd., Fengshan Dist., Kaohsiung City 83075, Taiwan

+886 7-262-6666

service@npac-weiwuying.org

### 0-5 Stage door

Ground floor access is from the north and east side of building. Enter from Operating office entrance on Sanduo 1st Road or Stage Door on Guotai Road.

Basement Level 1 access is from Sanduo 1st Road entrance for Opera House and Playhouse, Guotai Road entrance for Concert Hall and Recital Hall.

Working pass will be required for entry.



### 0-6 Auditorium / Seating

Seating Capacity : 1981 seats

2021/05/13

- House Seats : 1662 seats (1F/253 seats 、 2F/858 seats 、 3F/551 seats)
- Wheelchairs Seats : 14 seats
- Companion Seats : 14 seats
- Choir Seats : 185 seats(include Wheelchairs 6 seats 、 Companion 6 seats)
- Control Area Seats : 27 seats
- Reserved Seats for FOH : 8 seats
- Obstructed View Seats : 71 seats(Non-ticketing)
- Partial View

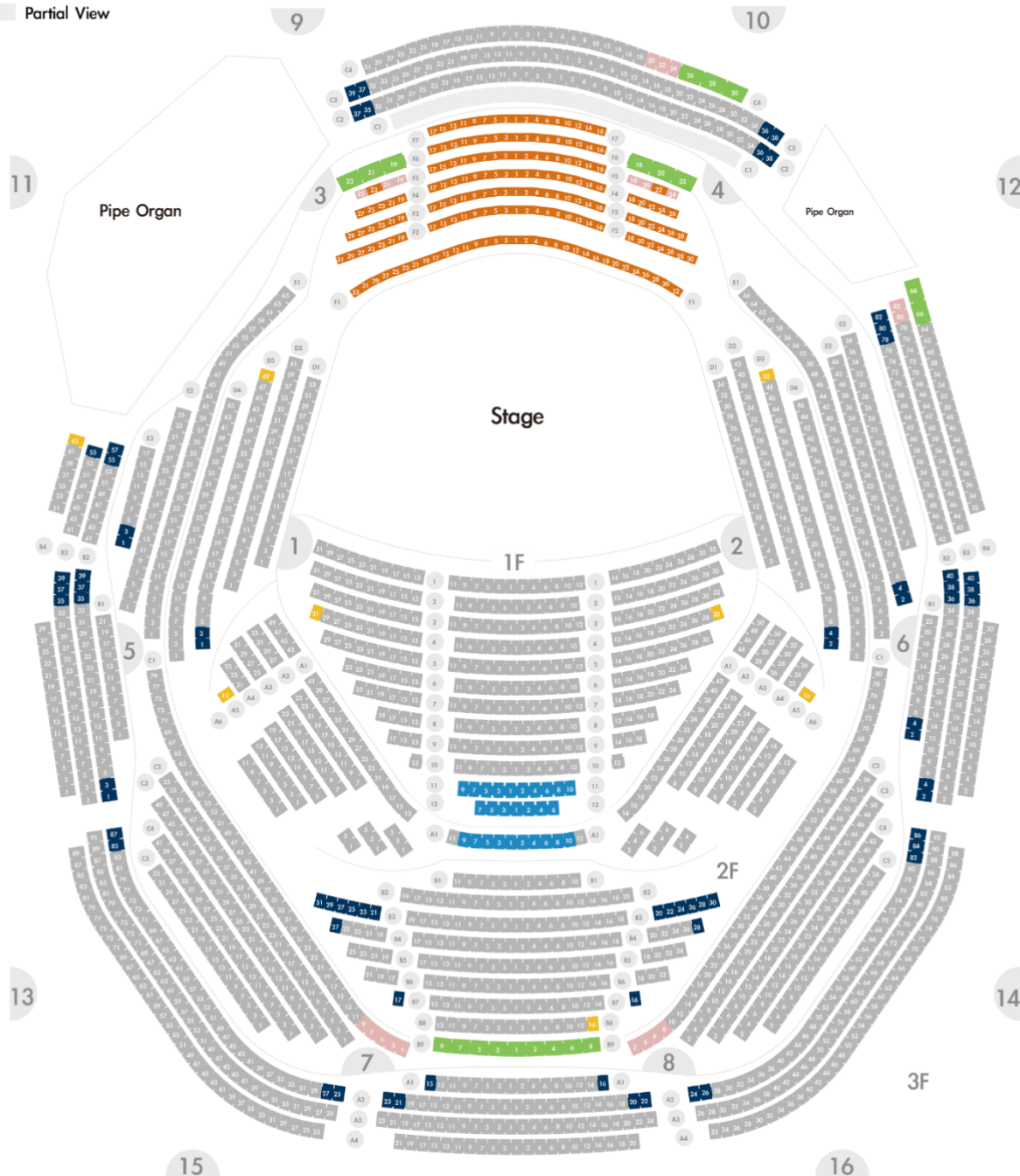

Figure 0.1- Concert Hall Seating plan

**Set Up Equipment Recommended Seat**

<b>Set Up Equipment Seat</b>	<b>Reserved Seat</b>	<b>Notes</b>
1st Floor 12 Row Seat 1	1st Floor 11 Row Seat 1、2、3 1st Floor 12 Row Seat 2、3 2nd Floor A1 Row Seat 1、2、3	For Photo Shooting & Video Shooting
2nd Floor B8 Row Seat 2	2nd Floor B7 Row Seat 1、2、4 2nd Floor B8 Row Seat 1、4	For Video Shooting
2nd Floor A1 Row Seat 49	2nd Floor A1 Row Seat 47 2nd Floor A2 Row Seat 31、33	For Photo Shooting & Video Shooting
2nd Floor A1 Row Seat 50	2nd Floor A1 Row Seat 48 2nd Floor A2 Row Seat 32、34	For Photo Shooting & Video Shooting
2nd Floor F1 Row Seat 1	2nd Floor F1 Row Seat 2、3 2nd Floor F2 Row Seat 1、3、5	For Video Shooting
2nd Floor F1 Row Seat 32	2nd Floor F1 Row Seat 30 2nd Floor F2 Row Seat 28、30	For Photo Shooting & Video Shooting
2nd Floor F1 Row Seat 33	2nd Floor F1 Row Seat 31 2nd Floor F2 Row Seat 29、31	For Photo Shooting & Video Shooting
<b>Set Up Control Area Seat</b>	<b>Reserved Seat</b>	<b>Notes</b>
1st Floor 11 Row Seat 1~10 1st Floor 12 Row Seat 1~7	2nd Floor A1 Row Seat 1~10	

0-7 Concert Hall Plan

# 音樂廳一樓化妝室位置圖

## Concert Hall 1F Dressing Room Map

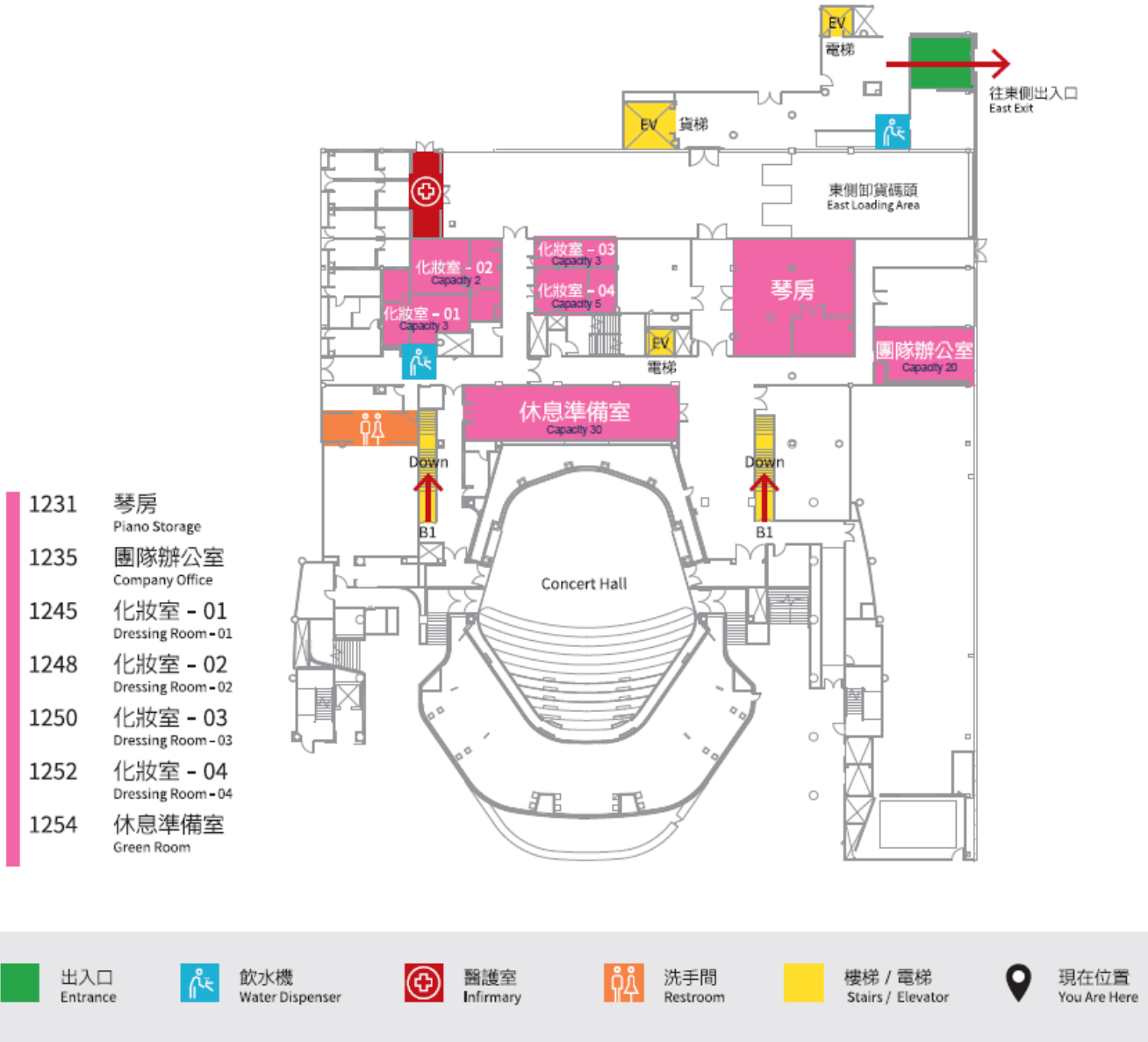
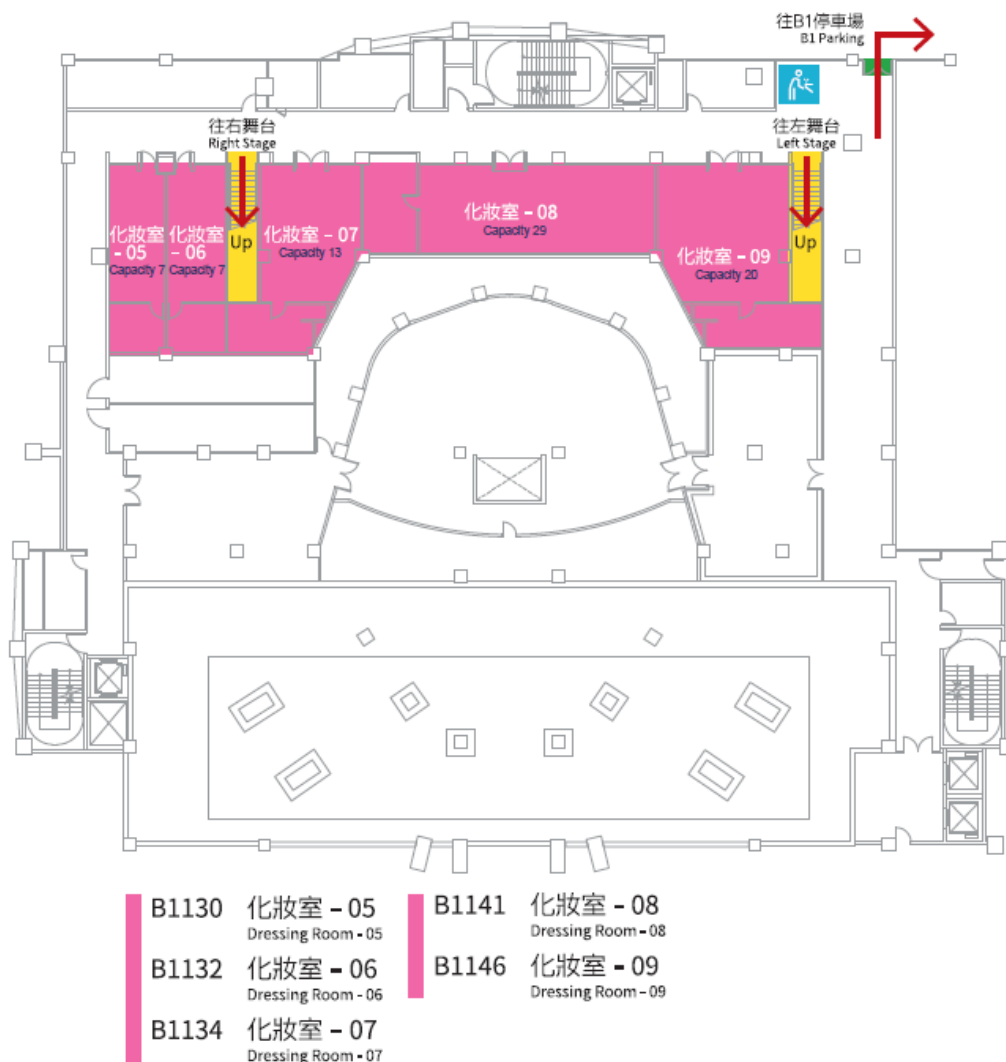

Figure 0.3- Concert Hall 1F plan



# 音樂廳地下一樓化妝室位置圖

## Concert Hall B1F Dressing Room Map



 出入口 Entrance	 飲水機 Water Dispenser	 醫護室 Infirmary	 洗手間 Restroom	 樓梯 / 電梯 Stairs / Elevator	 現在位置 You Are Here
---	--	--	---	--	--

Figure 0.4- Concert Hall B1 plan

0-8 Concert Hall Section

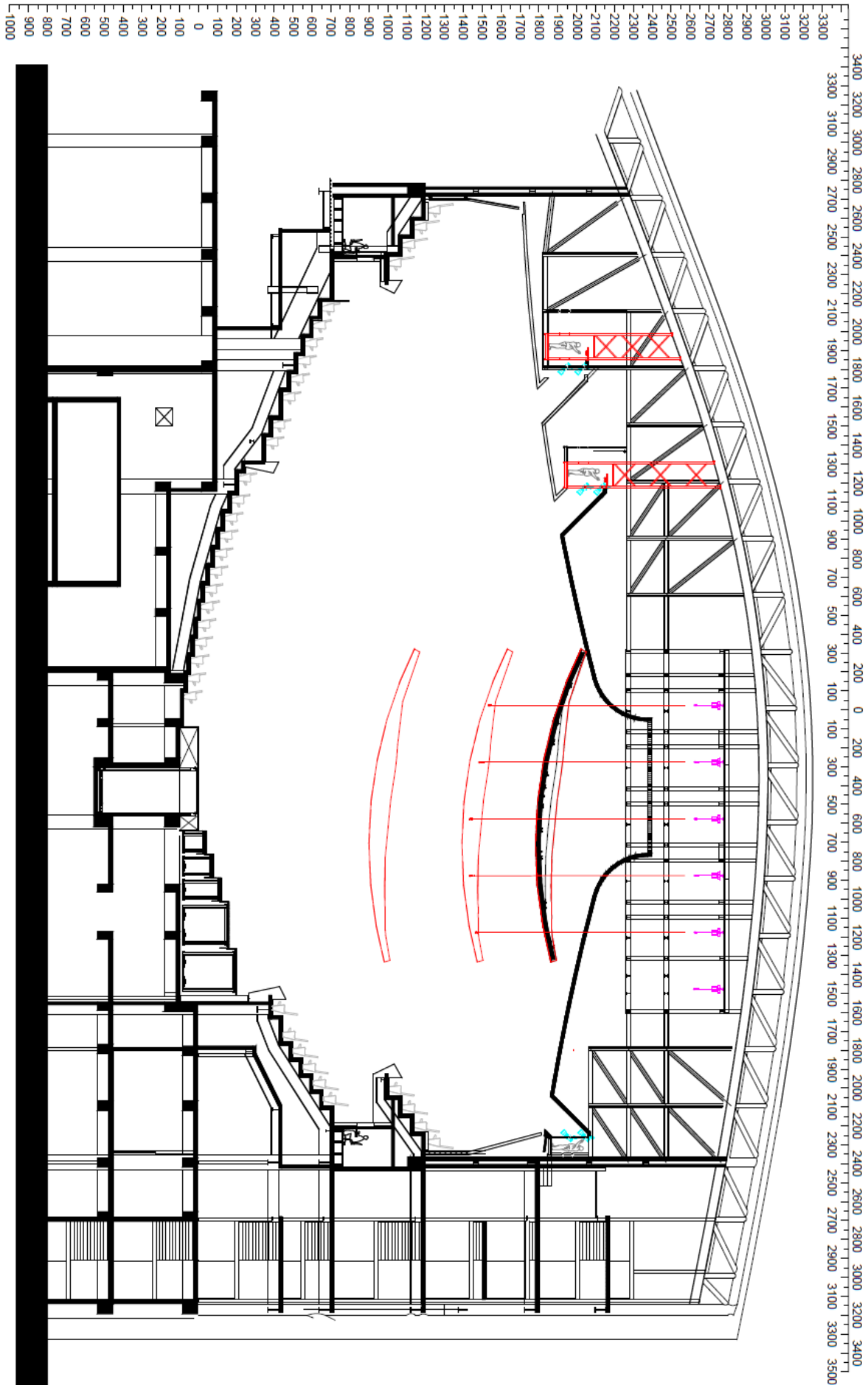

Figure 0.5- Concert Hall Section

# 1 Stage

## 1-1 Stage

20.8m (Width) x 13.6m (depth) x 0.8m (height from auditorium floor to stage level)  
 The stage area is 223.9 m<sup>2</sup>

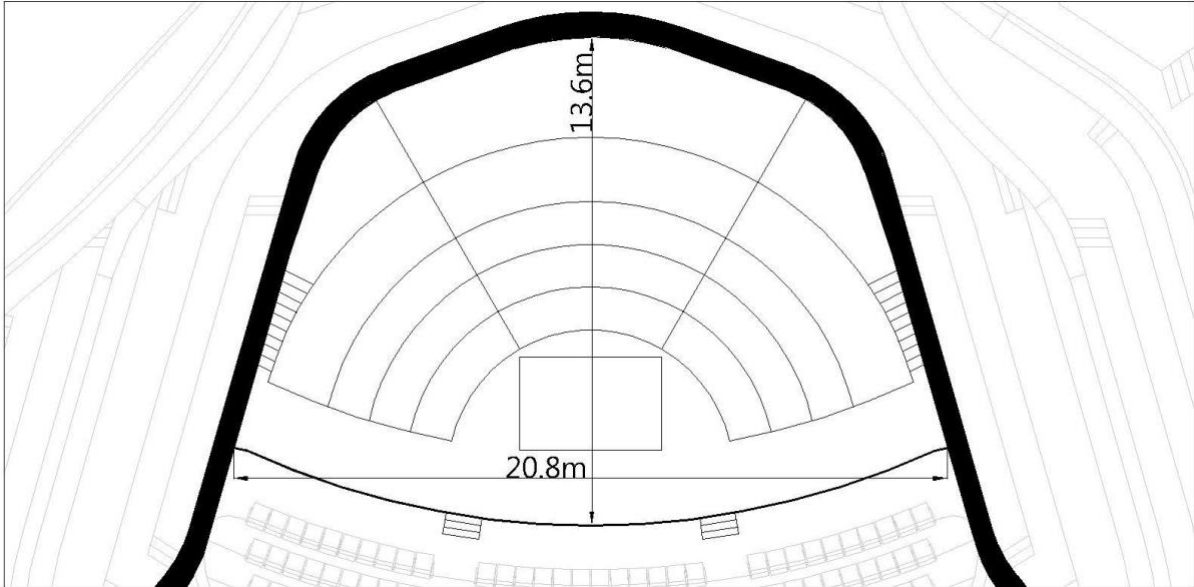

Figure 1.1-Stage Plan

## 1-2 Hoisting

### 1-2-1 Chain hoist (load 1000kg, fixed speed: 9.6m/min)

Above Stage, 24 sets, operation length 30m, Movecat chain hoist  
 Hoist can be connected to the main controller from both sides of the stage.

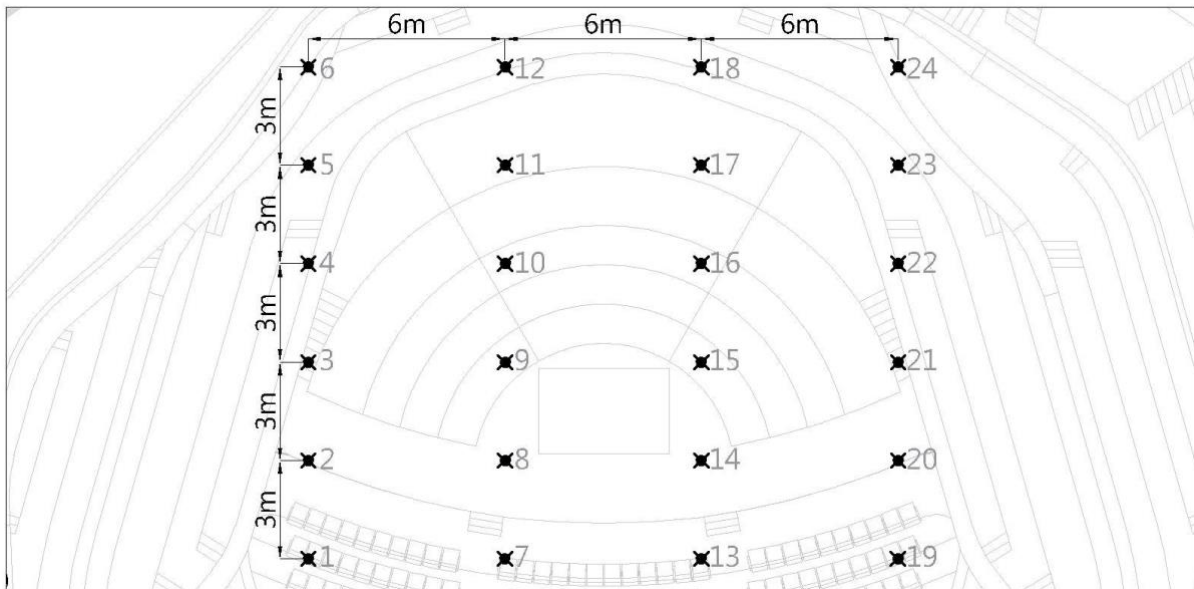

Figure 1.2 - Stage Hoisting plan

### 1-2-2 Trusses

Item	Quantity	Dimension	Paid Item
EUROTRUSS HD33 (Triangle)	27	0.29m( equilateral triangle length ) x 0.25m(Height) x 4 m( length )	*
	4	0.29m( equilateral triangle length ) x 0.25m( Height) x 3 m( length )	*

### 1-3 Stage Elevation Platform

Stage elevation platform consists of a center stage and five rows of platforms (15 arc platforms). Platforms can be adjusted for different orchestral formations and performance.

The marked lengths and widths below are the maximums; the actual area are shown in square meters.

Position	Platform number	Dimension(Length x Width , Area )	Platform elevation height limit (from stage level)
Row 1	No.1- No.3	1.2m x 4.73m, 5 m <sup>2</sup>	40cm
Row 2	No.4- No.6	1.2m x 5.93m, 6 m <sup>2</sup>	80cm
Row 3	No.7- No.9	1.2m x 7.13m, 8 m <sup>2</sup>	120cm
Row 4	No.10 - No.12	2.4m x 9.53m, 21 m <sup>2</sup>	160cm
Row 5	No.13 / No.15	4.65m x 1.0m/2.8m, 9 m <sup>2</sup>	200cm
	No.14	2.7m x 9.53m/12.1m, 28.5 m <sup>2</sup>	
Center Stage		3.8m x 2.4m, 9.12 m <sup>2</sup>	-455cm

Capacity:      Static: 500kg/ m<sup>2</sup>  
                   Dynamic : 250kg/ m<sup>2</sup>

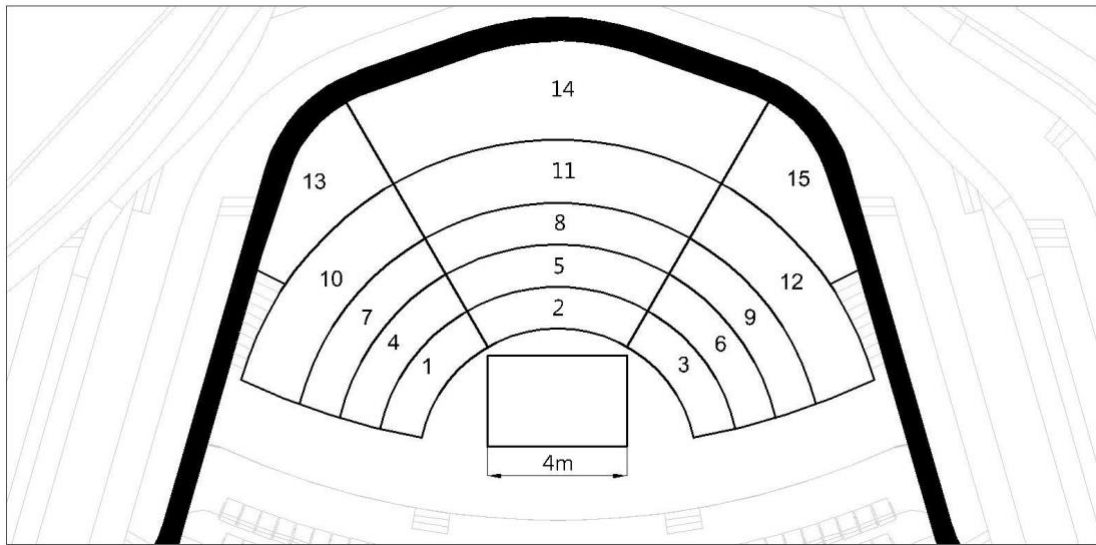

Figure 1.3 – Stage Elevation Platform plan

### 1-4 Acoustic Panel

The acoustic panel is placed above the stage, with the size of 16m in length, 16.6m in width and the total area of 200 m<sup>2</sup>. Elevation starts from 0.05m to 17.8m. The set heights are 9m, 14m and 17.8m.

Equipped with 67 sets of ETC S4 PAR

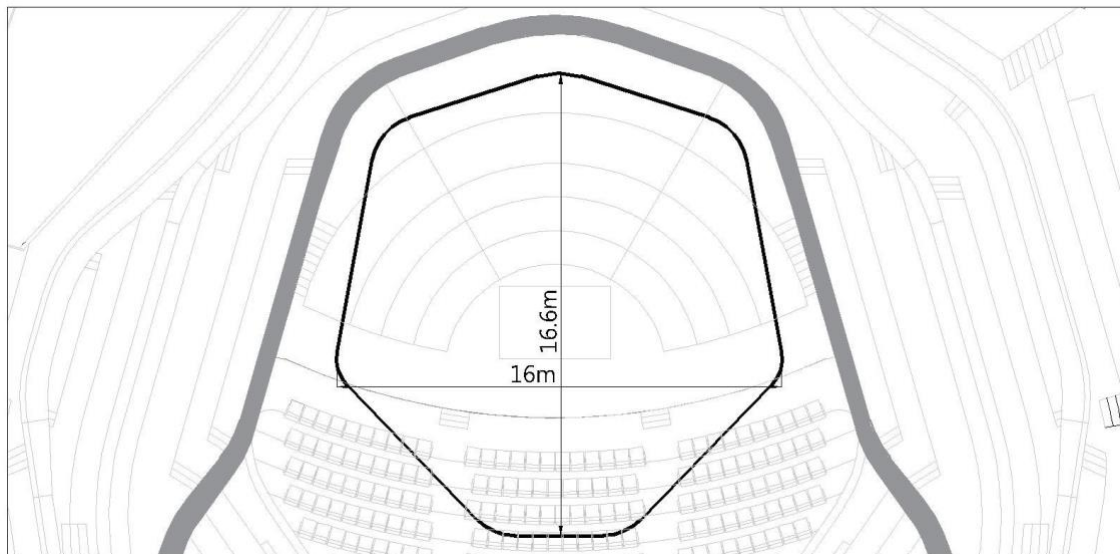

Figure 1.4- Acoustic Panel Plan

## 2 Lighting

### 2-1 Lighting System

The basic lighting for stage area is fixedly built in the Acoustic Panel, also provide 9 openable catwalk openings, which can be opened individually by the lighting requirements of the show.

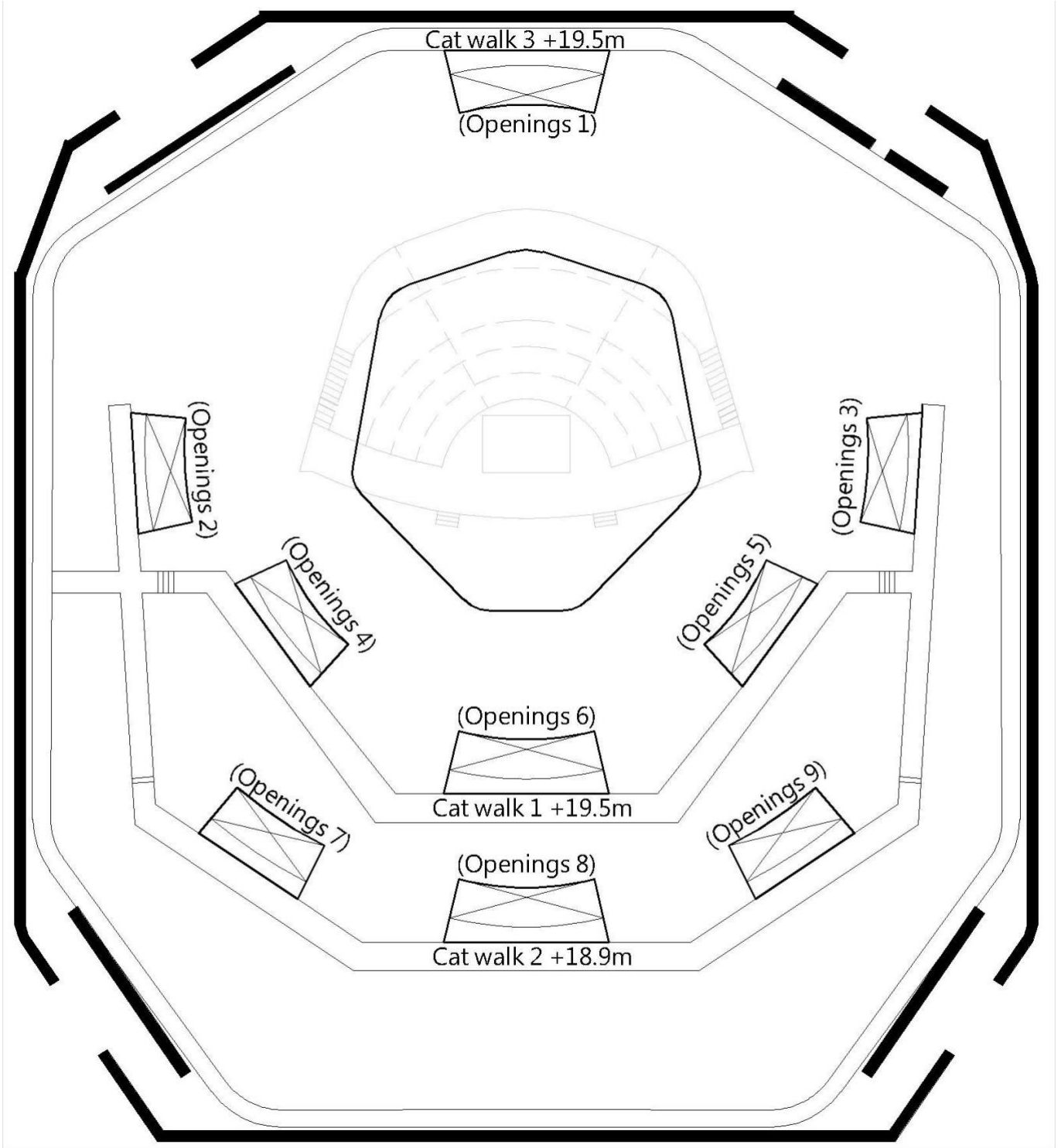

Figure 2.1 - Lighting Openings Position Plan

## 2-2 Lighting Instrument



*Important : All lighting data is on network system.*

Item	Position	Model	Specifications	Quantity	Frame Size	Note	Paid Item	
Lighting Console	Master Control Booth	GrandMA 2 Ultra Light		1				
	Sub Master Control Booth			1				
Dimmer System	Dimmer Room	State Automation Solution	220V 3kW/Circuit	256ch				
Ellipsoidal Reflector Spotlight	Openings 1	Selecon SPX 19°	200V/800W	2	15.8x15.8cm			
		Selecon SPX 15°-35°		12				
	Openings 2	Selecon SPX 19°	200V/800W	8	15.8x15.8cm			
		Selecon SPX 15°-35°		2				
	Openings 3	Selecon SPX 19°	200V/800W	8	15.8x15.8cm			
		Selecon SPX 15°-35°		2				
	Openings 4	Strand Leko Lite 10°	200V/800W	8	30.5x30.5cm			
	Openings 5	Strand Leko Lite 10°	200V/800W	8	30.5x30.5cm			
	Openings 6	Selecon SPX 14°	200V/800W	10	15.8x15.8cm			
		Selecon SPX 15°-35°		2				
	Openings 7	Strand Leko Lite 10°	200V/800W	7	30.5x30.5cm			
	Openings 8	Strand Leko Lite 10°	200V/800W	6	30.5x30.5cm			
		Selecon SPX 14°		6	15.8x15.8cm			
		Selecon SPX 15°-35°		2				
	Openings 9	Strand Leko Lite 10°	200V/800W	7	30.5x30.5cm			
	Stage Fixed at Acoustic Panel	Ovation P-56WW	220V/230W	67	19.1x19.1cm			
	2KW Fresnel Spotlight 8"	Storage	Selecon SPX 5°	220V/800W	10	24.5x24.5cm		
			Selecon SPX 14°		1	15.8x15.8cm		
			Selecon SPX 19°		16			
Parabolic Aluminized Reflector Spotlight		Selecon Arena Theatre 8" Fresnel 7°-60°	220V/2kW	30	24.5x24.5cm			
		PAR 64-Kupo PL-64LB	220V/1kW	48	25.4x25.4cm	Lamp : M x 48		
Long Throw Follow Spot	Openings 7 Openings 9	Robin BMFL Followspot LT	220V/1.7Kw	2				
LED Colorpanel RGBW *Used for Organ only.	For Organ	Stage One 5400 Color Panel-C4	110-220V/ 4A-2A 440W	8			*	
Follow Spot Operator			Operator/ 4 Hour	1			*	

*Items with \* mark are paid items. Please refer to the rate tables of National Kaohsiung Center for the Arts.*



2-3 Accessories

Item	Specifications	Size	Quantity
Barn Door	2kW Fresnel		6
Iris	For Selecon Ellipsoidal Reflector Spotlight		16
Gobo Holder	For Selecon Ellipsoidal Reflector Spotlight	B Size	40
Power Distribution Box	8CIR CEE Form Female Plug 		15
Multi-Cable	16pin Multi-Cable Harting Connector	5m	13
		10m	3
		15m	3
Ex-Cable	CEE16A	1.5m	19
		2m	30
		3m	17
		5m	9
		10m	6
		15m	8
Adapter Cable	CEE 16A(M) To Stage-Pin(F)		20
MA2 2 Port Node			1

Key	Legend	Quantity	Brand and Model
	Ellipsoidal 14°	16	Philips Selecon SPX 14°
	Ellipsoidal 19°	18	Philips Selecon SPX 19°
	Ellipsoidal 15°-35°	20	Philips Selecon SPX 15°-35°
	Ellipsoidal 10°	36	STRAND LEKO LITE 10°
	1.7kw Bobin BMFL Followspot LT	2	1.7kw Bobin BMFL Followspot LT

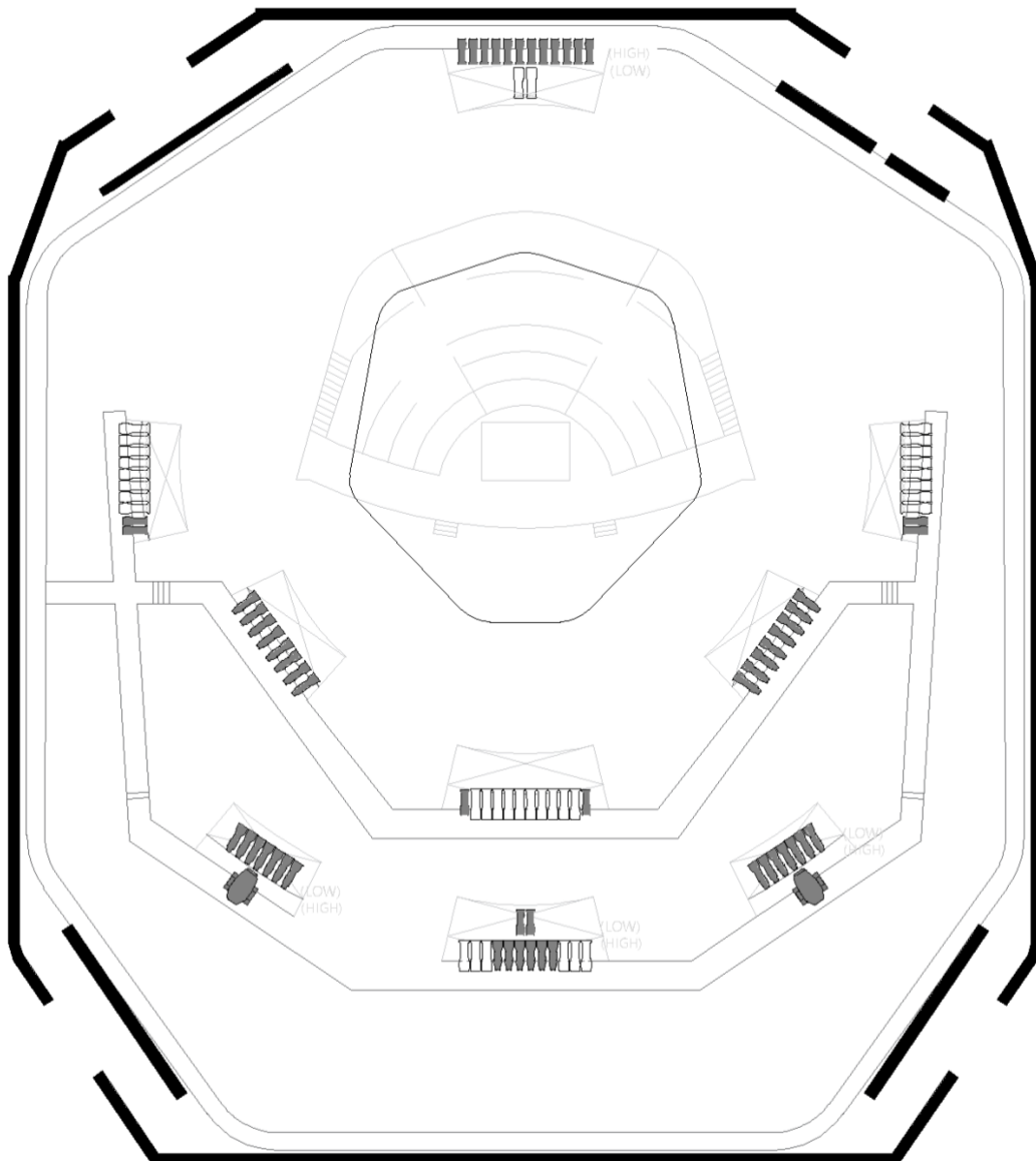

Figure 2.2- FOH Lighting Plan

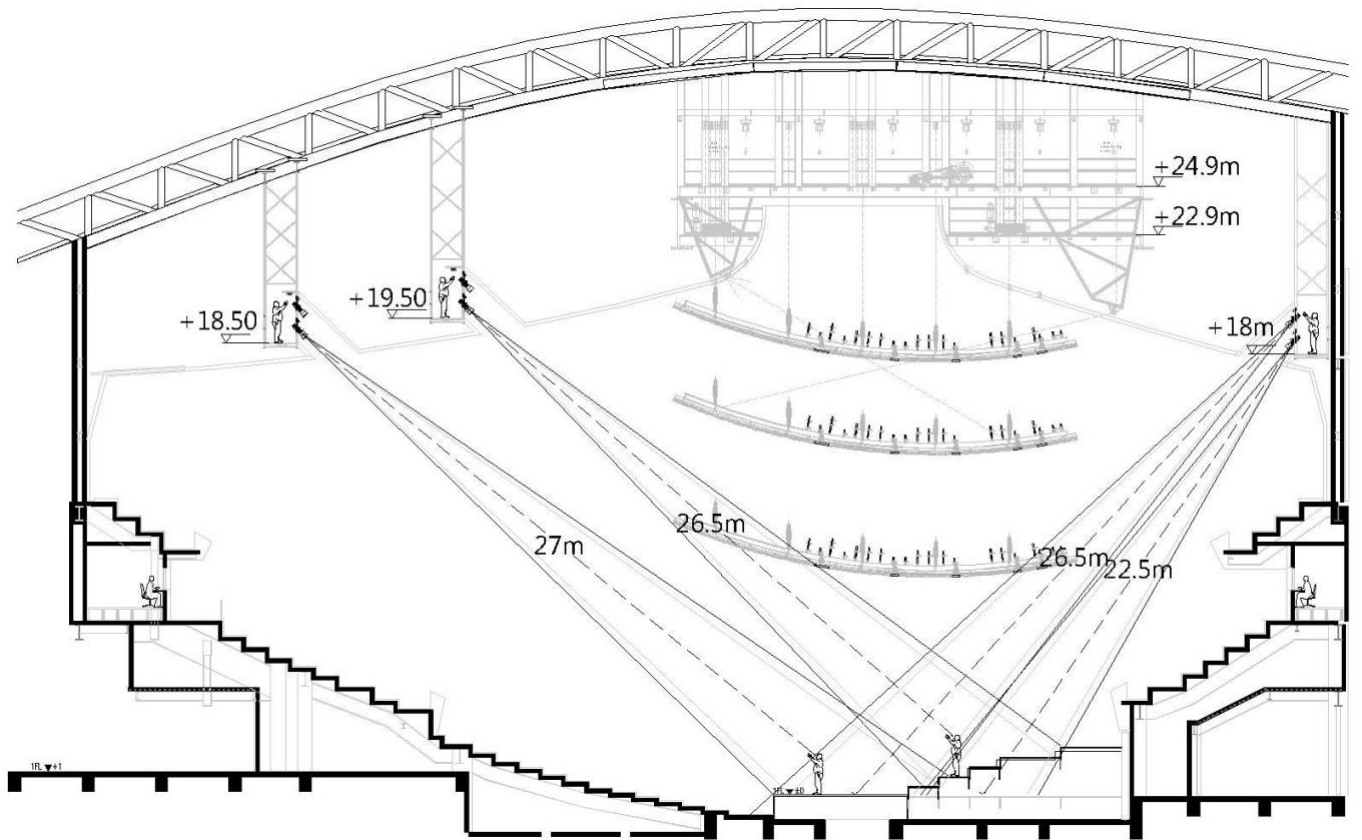

Figure 2.3- Lighting Section

## 2-4 Lighting Circuit

### 2-4-1 Stage area

Area and Position	Dimmer Circuit No.	Load	Network Circuit No.
Down Stage/L	001 ~ 008	3kW	LN01~LN02
	009 ~ 016		
Down Stage/R	017 ~ 024	3kW	LN03~LN04
	025 ~ 032		
Stage Right Waiting Area			LN05~LN08
Under Auditorium 12 rows			LN09~LN16

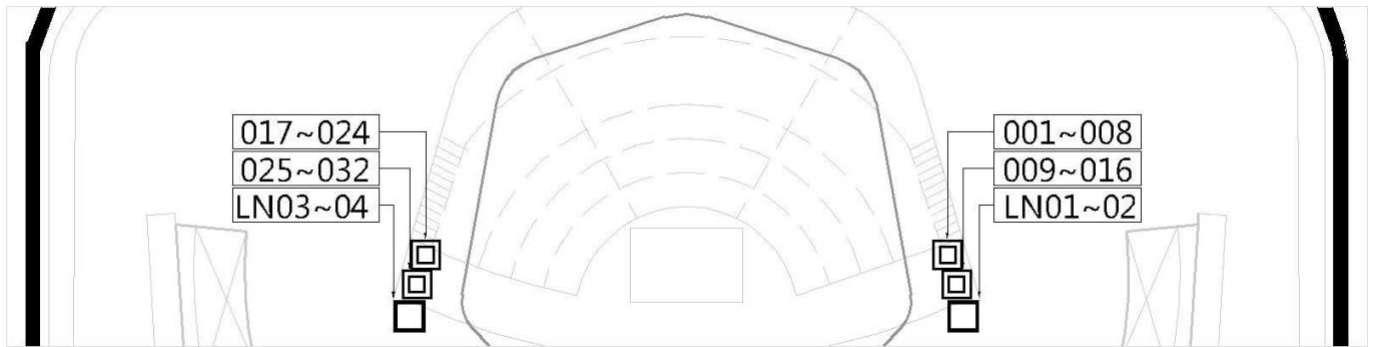
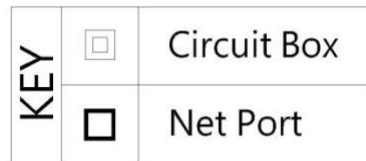

Figure 2.4.1- Stage Area Lighting Circuit Layout

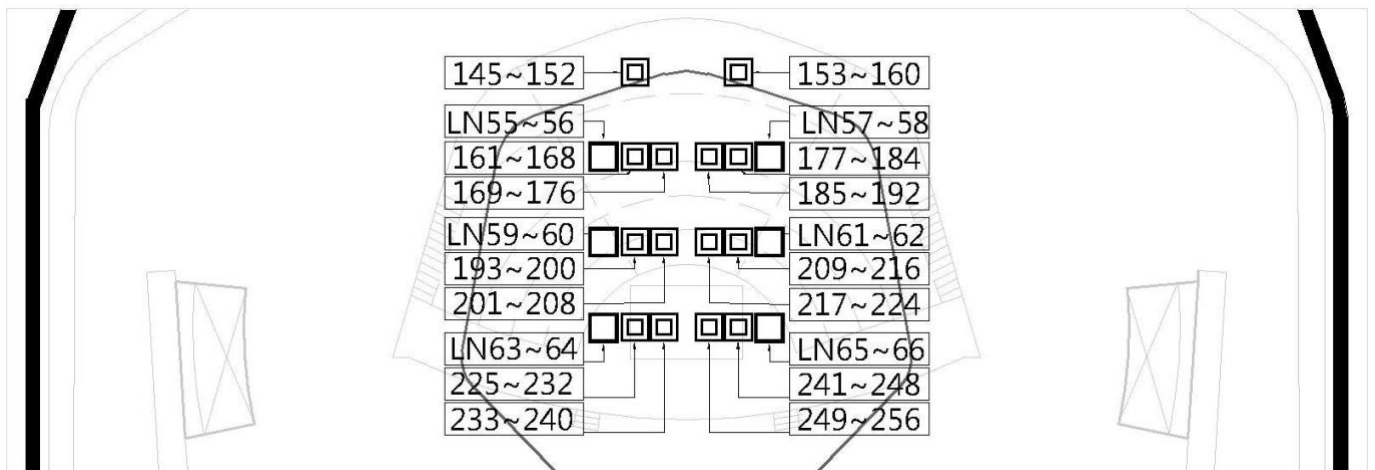

Figure 2.4.2 Grid Area Lighting Circuit Layout

2-4-2 Front of House

Area and Position		Dimmer Circuit No.	Load	Network Circuit No.	
Master Control Booth				LN21~ LN24	
Sub Master Control Booth				LN25~LN32	
Openings 1	3 rd. Catwalk -Rear Stage	129 ~ 132	3kW	LN53~LN54	
		133 ~ 136			
		137 ~ 140			
		141 ~ 144			
Openings 2	Lighting Box/R	045 ~ 048	3kW	LN39~LN40	
		049 ~ 052			
		053 ~ 056			
Openings 3	Lighting Box/L	033 ~ 036	3kW	LN37~LN38	
		037 ~ 040			
		041 ~ 044			
Openings 4	1st. Catwalk-Stage/R	081 ~ 084	3kW	LN45~LN46	
		085 ~ 088			
		089 ~ 092			
Openings 5	1st. Catwalk-Stage/L	057 ~ 060	3kW	LN41~LN42	
		061 ~ 064			
		065 ~ 068			
Openings 6	1st. Catwalk -Center	069 ~ 072	3kW	LN43~LN44	
		073 ~ 076			
		077 ~ 080			
Openings 7	2nd. Catwalk- Stage/R	105 ~ 108	3kW	LN49~LN50	
		109 ~ 112			
		113 ~ 116			
Openings 8	2nd. Catwalk -Center	117 ~ 120	3kW	LN51~LN52	
		121 ~ 124			
		125 ~ 128			
Openings 9	2nd. Catwalk - Stage/L	093 ~ 096	3kW	LN47~LN48	
		097 ~ 100			
		101 ~ 104			
Acoustic Panel	Grid-Up Stage	145 ~ 152	3kW		
		153 ~ 160			
Stage Grid Area	Grid-Up S.R.	161 ~ 168	3kW	LN55~LN56	
		169 ~ 176			
	Grid-Up S.L.	177 ~ 184	3kW	LN57~LN58	
		185 ~ 192			
	Grid-Center S.R.	193 ~ 200	3kW	LN59~LN60	
		201 ~ 208			
	Grid- Center S.L.	209 ~ 216	3kW	LN61~LN62	
		217 ~ 224			
			225 ~ 232	3kW	
			233 ~ 240		
	Grid- Down S.L.		241 ~ 248	3kW	LN65~LN66
			249 ~ 256		

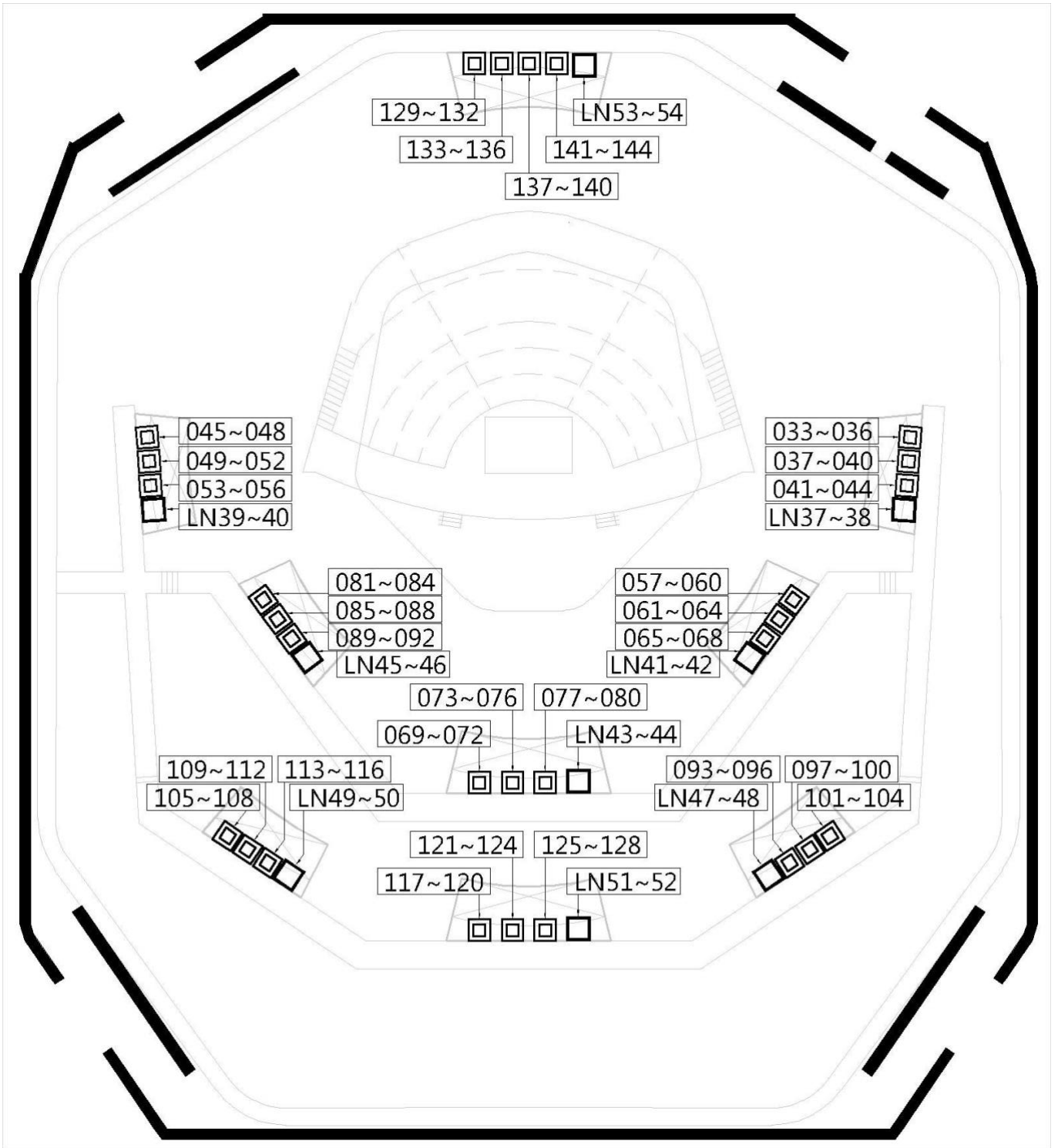

Figure 2.4.3- FOH Lighting Circuit Layout



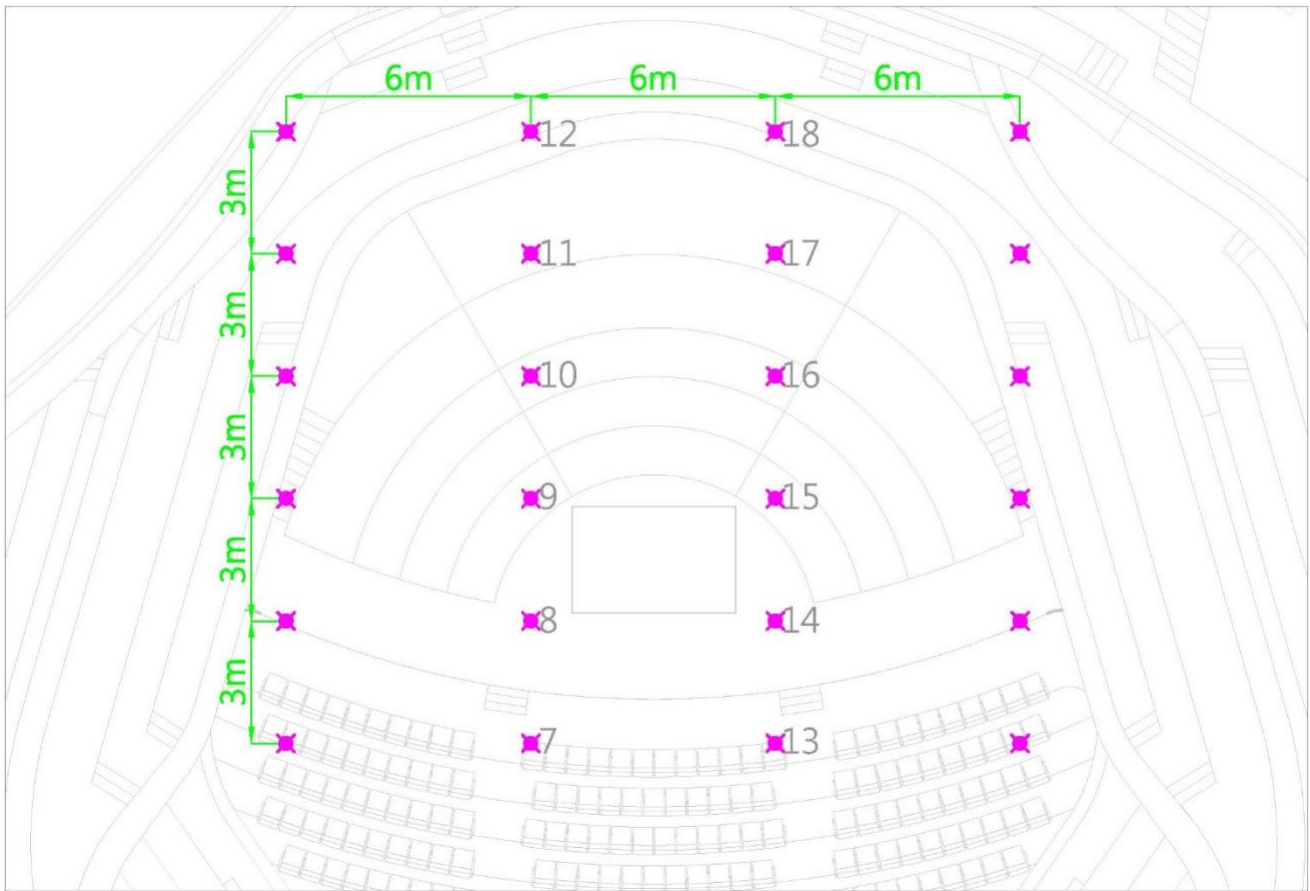

Figure 2.4.4- Chain hoist / Cable outlet

### 2-5 Portable Lift

Brand and Model : Snorkel UL-40 (Battery Power Supply)  
 Maximum height: 12.1m  
 Maximum weight: 136kg  
 Quantity: 1

### 2-6 Additional Power Supply

Function	Position	Specifications	Quantity
Stage	Stage Left / Right	3 ϕ 4W+G 380V/220V/60Hz (CEE 125A/3P+N+E)	1/1
Light		3 ϕ 4W+G 208V/120V/60Hz (Camlock 250A)	1/1
Sound		3 ϕ 4W+G 208V/120V/60Hz (Camlock 50A)	1/1

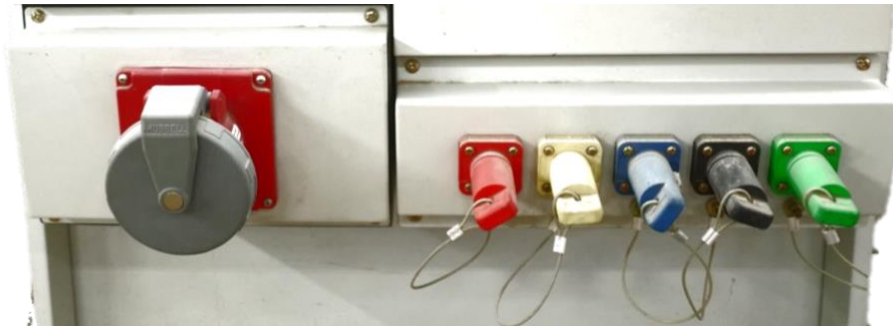

Figure 2.5.1 - Additional Power Supply

Floor	Seat NO.	CEE32A	CEE16A	Edison Connector	Network Circuit NO.
2F Choir Seat	F1-30	1 Output/30A	1 Output/15A	2 Output/15A	LN201
	F1-31	1 Output/30A	1 Output/15A	2 Output/15A	LN202
3F Seat	B2-82		2 Output/15A	2 Output/15A	LN303
	B2-57		2 Output/15A	2 Output/15A	LN304



Figure 2.5.2 - Additional Power Supply

### 2-7 Working Light / Auditorium Light / Blackout

#### Working Light

Work lights provided white and blue light mode, and the control switch is located on the stage manager' s Desk.  
 Lighting area: Side stage entrance, Stage machine pit, Grid area and Cat walk.

#### Auditorium lights

Auditorium lights consists houselights and step lights, which can be separately controlled and dimmed. The control panel is located on the stage manager' s Desk and lighting control room.

#### Blackout

In accordance with government Fire Services Act, there are many of emergency lights in the venue. We cannot extinguish the emergency lighting for any performance, there will be the minimal lighting levels in the auditorium and backstage areas.

## 3 Audio/Video Systems

### 3-1 Audio Facilities

Item	Quantity	Brand and Model	Paid Item
Digital mixer	1	Studer Vista 5 M3/32	
Digital speaker	2	Renkus-Heinz ICONYX IC24RII	
Digital speaker	2	Renkus-Heinz ICONYX IC16RII	
Digital speaker	8	Renkus-Heinz ICONYX IC8RII	
Stage front speaker	7	Renkus-Heinz CFX41	
12" Stage Active speaker	8	Renkus-Heinz PN121M/12	*
6.5" Stage Active speaker	8	Renkus-Heinz PN61	*
Digital I/O Fiber Module	2	Studer D21M	
Dual channel Equalizer	4	BSS FCS 960	*
Stereo audio converter	1	Whirlwind PcUSB 2-Channel USB Direct Box	

Items with \* mark are paid items. Please refer to the rate tables of National Kaohsiung Center for the Arts.

### 3-2 Control Room

Item	Quantity	Brand and Model	Paid Item
Main Digital mixer	1	Studer Vista 5 M3/42	
Digital I/O Fiber Module	1	Studer D21M	
CD PLAYER	1	Tascam CD-500B	*
CD-R PLAYER	1	Tascam CD-RW 901 MKII	*
Multitrack Recording equipment	1	Joeco BBR1D+2.5" USB 1TB HD	*
Dual track Hard disk recorder	1	Tascam DA 3000	*
Active speakers	4	Dynaudio BM12 MkIII	

Items with \* mark are paid items. Please refer to the rate tables of National Kaohsiung Center for the Arts.

### 3-3 Stage Manager' s Console

The stage manager' s console is equipped with a near-field monitor speaker, stage video monitors, synchronous show screens with lighting and flying system controller, communication system and live announcements to individual space in backstage.

### 3-4 Machine Room

Item	Quantity	Brand and Model	Note
Digital Audio Management	1	Studer D21M (Studer Score Live)	
Digital I/O Fiber Module	1	Studer D21M	

### 3-5 Microphone

Item	Quantity	Brand and Model	Paid Item
Dynamic microphone	2	Audio Technica AE4100	*
Dynamic microphone	6	Audio Technica ATM250	*
Condenser microphone	2	Audio Technica AE5400	*
Cardioid Condenser microphone	6	Audio Technica AT4021	*
Cardioid Condenser Boundary Microphone	4	Audio Technica U851R	*
Stage reception Microphone	2	DPA 4017B / DPA UA0836 Holders	
Hypercardioid Condenser microphone	8	AKG CK63-ULS+ C480B	*
Cardioid condenser microphone	8	AKG CK61-ULS + C480B	*
wireless microphone	4	Sennheiser SKM500G3+MME865	*
Mini wireless microphone	8	Sennheiser SK500G3+MKE2	*
Single channel wireless microphone receiver	12	Sennheiser EW500G3	
Wireless microphone wave antenna	2	Sennheiser AD3700	
Wave antenna distributor	3	Sennheiser ASA1	

Items with \* mark are paid items. Please refer to the rate tables of National Kaohsiung Center for the Arts.

### 3-6 Communications

Item	Quantity	Brand and Model	Paid Item
Intercom host machine	1	Clear-Com Eclipse HX-Delta	
System interface	1	Clear-Com Helixnet HMS-4X	
Double circuit intercom	7	Clear-Com Helixnet HBP-2X	
Fixed intercom microphone/ speak	1	Clear-Com V12PDXY 110 / 340 Clear-Com V12PDDXY 110 / 340	
Single head receiver microphone	4	Clear-Com CC-300	
Double head receiver microphone	3	Clear-Com CC-400	
Telephone intercom	4	Clear-Com HS-6	
Digital Wireless Intercom set	4	1. Portable wireless sub-station / Clear Com FS BP 2. Single-ear headset / Clear Com CC 300	*

Items with \* mark are paid items. Please refer to the rate tables of National Kaohsiung Center for the Arts.

### 3-7 Locations of Communications

Each floor is paired with intercom system, 27units in total.

Item Number	Floor	Location
1	B1F	Storage room
2	1F	Stage left preparation area
3		Stage right preparation area
4		Stage left
5		Stage right
6		Auditorium seating area 12 row
7		Loading Dock
8		Sound room
9		Recording studio
10		Green room 1
11		Dressing room 2
12		Dressing room 3
13		Dressing room 4
14		2MF
15	Master control room	
16	Deputy Control Room	
17	4F	Dimmer room
18		Amplifier room
19	R1F	Catwalk 1 <sup>st</sup> (Lightingopen4)
20		Catwalk 1 <sup>st</sup> (Lightingopen5)
21		Catwalk 1 <sup>st</sup> (Lightingopen6)
22		Catwalk 1 <sup>st</sup> (Lightingopen7)
23		Catwalk 2 <sup>st</sup> (Lightingopen8)
24		Catwalk 2 <sup>st</sup> (Lightingopen9)
25		Stageright Box(Lightingopen3)
26		Stageleft Box(Lightingopen2)
27		Catwalk(Lightingopen1)

### 3-8 Stage Cameras and Video Surveillance Systems

Stage monitors are installed in right and left stage entrances, first, second, and third floor lobbies, master and secondary control rooms, dressing rooms and green rooms.

Item	Quantity	Brand and Model	Paid Item
Camera ( 2/3 inch 3CCD )	2	Panasonic AW-HE870 Panasonic LZ20M85G	
Remote control	1	Panasonic AW-RP50	
Switcher	1	Panasonic AW-RP120	
Video recording	Show	Fixed camera for stage panoramic view recording, only suitable for archived copy.	

Items with \* mark are paid items. Please refer to the rate tables of National Kaohsiung Center for the Arts.

### 3-9 Paging Systems

#### Backstage Paging Systems

There are four venues individually Backstage Paging Systems in National Kaohsiung Center for the Arts. For Concert Hall paging available to all dressing rooms, green rooms, Company office and passage,it can also available paging to separately 5 zones. The Paging and Program position is located on the stage manager' s console.

Zone 1 : 1235 Company office

Zone 2 : 1254 Green Room · B1130 Dressing Room-05 · B1132 Dressing Room-06 · B1134 Dressing Room-07 · B1141 Dressing Room-08 · B1146 Dressing Room-09

Zone 3 : Passage B1126

Zone 4 : Passage (1230 · 1240 · 1233 · 1255 · 1256 · 1257)

Zone 5 : 1244 Green Room-01 · 1245 Dressing Room-01 · 1247 Green Room-02 · 1248 Dressing Room-02 · 1250 Dressing Room-03 · 1252 Dressing Room-04 · 1255A Conductor Dressing Room

**3-10 Projector**

Item	Quantity	Brand and Model	Paid Item
Laser Projector/ Downlight type (Dedicated to Subtitle)	1	1. 2 Panasonic(Space Player) 、 2 Laptop 、 1 Switcher 2. Include installation. 3. After second performance will discount 50%	*

*Items with \* mark are paid items. Please refer to the rate tables of National Kaohsiung Center for the Arts.*



## 4 Backstage

### 4-1 Dressing Room and Green Room

No.	Floor	Room No.	Name	Capacity	Notes
1	1	1235	Company office	20	Includes table and chairs.
2		1245	Dressing room 01	3	Includes mirror, table and chairs, toilet and shower
3		1248	Dressing room 02	2	Includes mirror, table and chairs, toilet and shower, piano
4		1250	Dressing room 03	3	Includes mirror, table and chairs, toilet and shower
5		1252	Dressing room 04	5	Includes mirror, table and chairs, toilet and shower
6		1254	Green room	30	Includes dressing mirror, table and chairs.
7	B1	B1130	Dressing room 05	7	Includes mirror, table and chairs and toilet
8		B1132	Dressing room 06	7	Includes mirror, table and chairs, toilet and shower
9		B1134	Dressing room 07	13	Includes mirror, table and chairs, toilet and shower
10		B1141	Dressing room 08	29	Includes mirror, table and chairs, toilet and shower
11		B1146	Dressing room 09	20	Includes mirror, table and chairs, toilet and shower

### 4-2 Orchestra Facilities

No.	Item	Quantity	Notes
1	Chair	150 *	
2	Bass Stool	18 *	
	Percussion Stool		
3	Conductor' s chair	1 *	
4	Music stand	140 *	
5	Music stand light	60 *	White light, two brightness mode
6	Conductor' s podium	1 *	WENGER Double podium / Base podium:1.09 x 0.97 x 0.15 m Double podium / Upper podium:0.81 x 0.97 x 0.15 m Single podium:1.2 x 1.15 x 0.25 m
7	Conductor' s stand	1	
8	Percussion table stand	8 *	
9	Endpin stopper	20 *	
10	Acoustic shield	5 *	
11	Platform	30 *	Large L183cm*W138cm*H22cm*10 Medium L183cm*W92cm*H22cm*10 Small L183cm*W46cm*H22cm*10
12	Resonance Podium for Violin 100*60*15(cm)	8 *	
	Resonance Podium for Violin 100*60*20(cm)	8 *	
	Resonance Podium for Cello 130*60*15(cm)	4 *	
	Resonance Podium for Cello 130*60*20(cm)	4 *	
	Solo Musician' s Podium 175*100*20(cm)	1 *	
	Solo Musician' s Podium 115*110*15(cm)	1 *	

Items with \* mark are shared with Recital Hall.

**4-3 Pianos (shared between four venues)**

No.	Item	Brand	Model Number	Quantity	Notes
1	Concert grand	Steinway & Sons	D-274	3	*
2	Concert grand	FAZIOLI	F308	1	*
3	Grand Piano	YAMAHA	C7XPE	1	*
4	Grand Piano	KAWAI	SK-6L	1	*
5	Celesta	Schiendmayer	5 ½ Octave Studio model	1	*
6	Harpsichord	J.C.NEUPERT	Hemsch	1	*
7	Pipe Organ	ORGELBAU KLAIS BONN		1	*
8	Upright Piano	YAMAHA	U3	1	*

Items with \* mark are paid items. Please refer to the rate tables of National Kaohsiung Center for the Arts.

**Important :**

Pianos shared with four venues, booking in advance is required.

WeiWuYing's contract-signed piano technician must tune all pianos before performance.(Piano hire fees do not include tuning costs)

While WWY' s piano is in part of the performance, the Fog and Haze Machine can' t be used.

4-4 Pipe Organ

Kaohsiung/TWN, National Kaohsiung Center for the Arts

<b>Symphonic Organ: V/102, mech.+elektr./elektr.</b>				<b>Classic Organ: II/25, mech.+elektr./elektr.</b>	
<b>I. POSITIF EXPRESSIF</b> C-c <sup>4</sup>	Hautbois	8'	Flûte	4'	
Quintaton	16'	Voix humaine	8'	Petite QUinte	2 2/3'
Montre	8'	Clairon	4'	Petite Flûte	2'
Salicional	8'	Trémolo		Piccolino	1'
Bourdon	8'	<b>IV. GRAND-CHŒUR</b> C-c <sup>4</sup>	Mixture VI	2 2/3'	Gedackt
Unda maris	8'	Principal	8'	Contre Bombarde	32'
Flûte ouverte	4'	Bourdon	8'	Bombarde I	16'
Violon	4'	Octave	4'	Bombarde II (SO)	16'
Chœur de Violes VI	2 2/3'	Nazard	2 2/3'	Trompette I	8'
Basson	16'	Quarte	2'	Trompette II (SO)	16'
Hom	8'	Tierce	1 3/5'	Clairon	4'
Chœur de Rossignols		Larigot	1 1/3'	<b>KOPPELN/COUPLERS</b>	
Trémolo		Septième	1 1/7'	Tirasse Positif expressif (I-P)	
<b>II. GRAND-ORGUE</b> C-c <sup>4</sup>	Sifflet	1'	Tirasse Grand-orgue (II-P)		
Montre	16'	Grosse Fourniture VI	2 2/3'	Tirasse Récit expressif (III-P)	
Bourdon	16'	Cymbale VI	1'	Tirasse Grand-cœur (IV-P)	
Montre	8'	Grosse Trompette	8'	Tirasse Solo (V-P)	
Salicional	8'	Cromorne	8'	Tirasse Chamades (CH-P)	
Flûte harmonique	8'	Gros Clairon	4'	Grand-orgue au Positif (II-I)	
Bourdon	8'	Trémolo		Récit au Positif expressif (III-I)	
Grosse Quinte	5 1/3'	<b>V. SOLO</b> C-c <sup>4</sup>	Grand-cœur au Positif (IV-I)		
Prestant	4'	Flûte majeur	8'	Solo au Positif expressif (I-P)	
Flûte ouverte	4'	Gambe	8'	Chamades au Positif expressif (CH-I)	
Grosse Tierce	3 1/5'	Voix céleste	8'	Positif au Grand-orgue (I-II)	
Quinte	2 2/3'	Flûte de Concert	4'	Récit au Grand-orgue (III-II)	
Septième	2 2/7'	Grande Bombarde	16'	Grand-cœur au Grand-orgue (IV-II)	
Doublette	2'	Trompette	8'	Solo au Grand-orgue (V-II)	
Cornet V	8'	Cor anglais	8'	Grand-cœur au Récit (IV-III)	
Fourniture VI	2'	Clairon	4'	Solo au Récit (V-III)	
Cymbale VI	1 1/3'	Chamade	16'	Chamades au Récit (Ch-III)	
Bombarde	16'	Chamade	8'	Solo au Grand-cœur (V-IV)	
Trompette	8'	Chamade	4'	Chamades au Grand-cœur (Ch-IV)	
Chamade (SO)	16'	<b>PÉDALE</b> C-g <sup>1</sup>	Octaves graves Positif (Sub in I)		
Chamade (SO)	8'	Voix de baleine	64'	Octaves aiguës Positif (Super in I)	
Chamade (SO)	4'	Flûte	32'	Octaves graves Grand-orgue (Sub in II)	
<b>III. RÉCIT EXPRESSIF</b> C-c <sup>4</sup>	Soubasse	32'	Octaves aiguës Grand-orgue (Super in II)		
Bourdon	16'	Basse acoustique	32'	Octaves graves Récit (Sub in III)	
Diapason	8'	Flûte	16'	Octaves aiguës Récit (Super in III)	
Flûte harmonique	8'	Principal-Basse (G-O)	16'	Octaves graves Grand-cœur (Sub in IV)	
Viole de Gambe	8'	Soubasse	16'	Octaves aiguës Grand-cœur (Super in IV)	
Voix céleste	8'	Bourdon (G-O)	16'	Octaves graves Solo (Sub in V)	
Octave	4'	Grosse Quinte	10'	Octaves aiguës Solo (Super in V)	
Flûte octaviante	4'		2/3'		
Nazard harmonique	2 2/3'	Flûte	8'		
Octavin	2'	Octave	8'		
Tierce harmonique	1 3/5'	Bourdon	8'		
Carillon IV	2 2/3'	Grosse Tierce	6 2/5'		
Cornet harmonique V	8'	Quinte	5 1/3'		
Bombarde	16'	Septième	4 4/7'		
Trompette harmonique	8'	Octave	4'		
					<b>I. HAUPTWERK</b> C-c <sup>4</sup>
					Quintadena
					16'
					Principal
					8'
					Gedackt
					8'
					Gamba
					8'
					Octave
					4'
					Quinte
					2 2/3'
					Superoctave
					8'
					Mixtur V
					1 1/3'
					Trompette
					8'
					<b>II. OBERWERK</b> C-c <sup>4</sup>
					Gedackt
					8'
					Quintadena
					8'
					Principal
					4'
					Rohrflöte
					4'
					Waldflöte
					2'
					Quinte
					1 1/3'
					Sesquialera II
					2 2/3'
					Scharff IV
					1'
					Dulcian
					8'
					Tremulant
					<b>PEDAL</b> C-g <sup>1</sup>
					Subbass
					16'
					Principal
					8'
					Gedackt
					8'
					Octave
					4'
					Hintersatz IV
					2 2/3'
					Fagott
					16'
					Trompette
					8'
					<b>KOPPELN/COUPLERS</b>
					II - I
					I - P
					II - P
					Generalspieltische /
					General Consoles:
					Hauptwerk - I
					Hauptwerk - II
					Hauptwerk - III
					Hauptwerk - IV
					Hauptwerk - V
					Hauptwerk - P
					Oberwerk - I
					Oberwerk - II
					Oberwerk - III
					Oberwerk - IV
					Oberwerk - V
					Oberwerk - P

### 4-5 Loading Dock/ Scenery Shipping Path / Loading Flow

#### 4-5-1 East Dock

Recital Hall and Concert Hall use the East Dock for loading and unloading. The dock is equipped with two hydraulic dock leveler that can be adjusted according to the required height.

##### Dock Dimension

Dimension : 8.75m (width)

Clearance : 4.3m height from floor to top

3.8m height from dock to grid area (Truck height limit 4.2m)

Height from dock to floor: 0.98m

Stage entrance: minimum 1.95m (width) x 2.2m (height)

##### ※Notes for Container Transport:

Due to the limitation of the slope at the entry of the loading dock, the minimum height of the trailer's low bed should be higher than 100cm. Also, if the company hires a 40' high-cube container, the bed rack should be within the height of 135~140cm to accommodate the height of loading gate.

#### 4-5-2 Handling equipment

1.5mt Stand-Up Automatic Electric Forklift x1

3mt Manual Hydraulic Pallet Jack x1

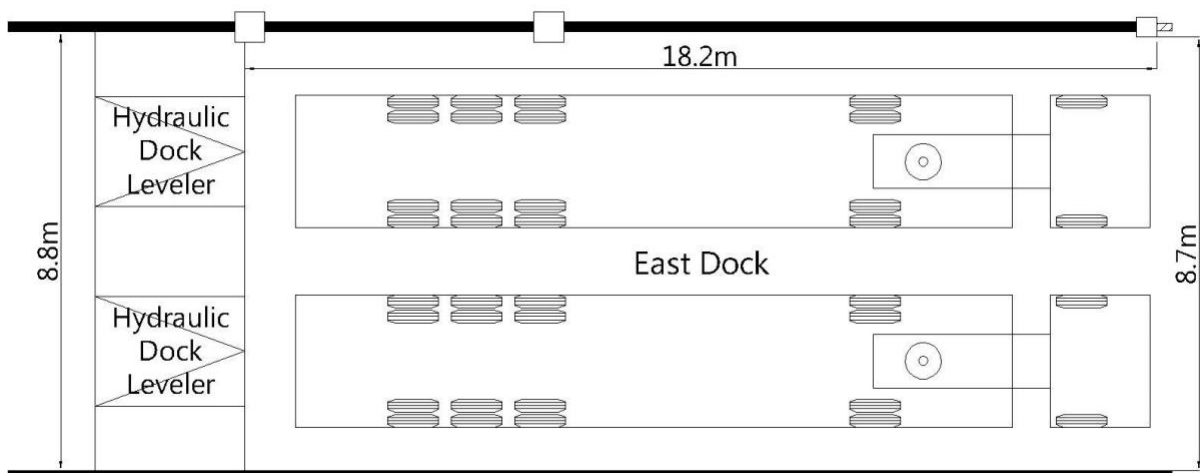

Figure 4.1- East Loading Dock Plan

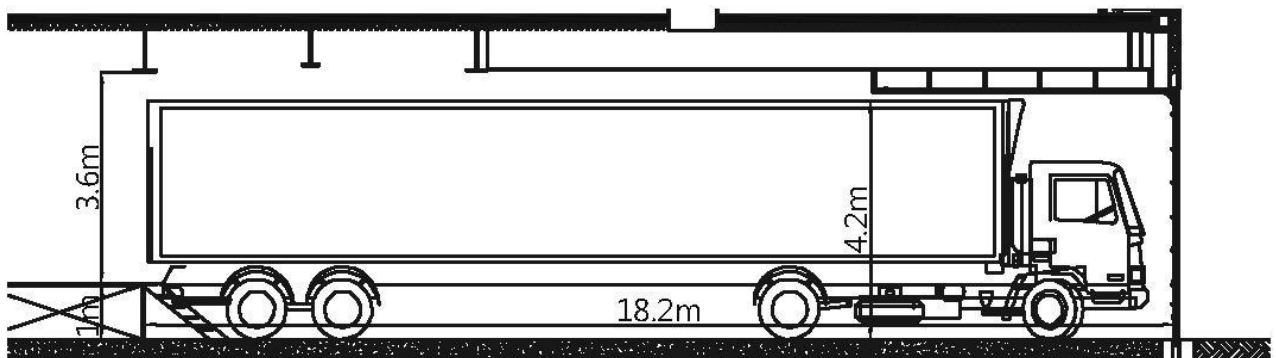

Figure 4.2- East Loading Dock Section

4-5-3 Loading Flow

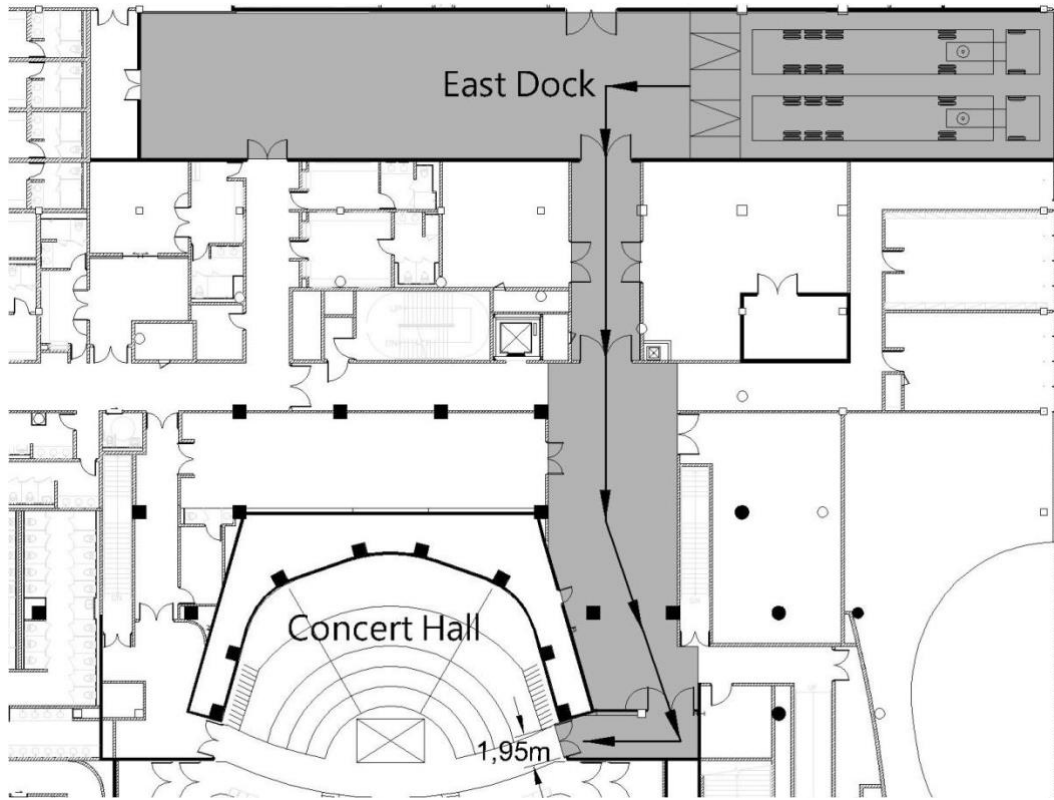

Figure 4.3 - Loading Flow

4-5-4 Hydraulic Dock Leveler

- Capacity: 22.6mt
- Area: 198cm (width) x 221.9cm (length)
- Elevation: +/- 30.5cm
- Quantity: 2 on east dock

## 4-6 Other Facilities

### 4-6-1 Rehearsal Rooms

There is no rehearsal studio dedicated to the Concert Hall. Additional rehearsal space is limited across the WEIWUYING. There are 13 different function and accommodated rehearsal studios, these available for hire between four major theatres .Requests should be discussed well in advance to determine availability. The hire fees please refer to the rate tables of National Kaohsiung Center for the Arts.

Room No.	Name	Dimension (Length x Width x Height / m)	Notes
1171	Rehearsal Studio-01	16.4x12.3x10.4	1. Grand Piano, Wooden floor covered black color dance floor, Wall mount glassless mirrors x 1 side 2. Capacity : 110
		Subsidiary space 6.9x5.3x3	
1182	Rehearsal Studio-02	11.4x10.8x3.8	1. Wooden floor covered gray color dance floor, Sound absorption wall x 2 side, Wall mount glassless mirrors x 2 side 2. Capacity : 50
1184	Rehearsal Studio-03	11.1x10.8x4	1. Grand Piano, Wooden floor covered gray color dance floor, Sound absorption wall x 2 side, Wall mount glassless mirrors x 2 side 2. Capacity : 50
1186	Rehearsal Studio-04	17.5x12.1x3.9	1. Grand Piano, Wooden floor, Black color dance floor, Wall mount glassless mirrors x 2 side, Fixed Ballet barre on the single sided wall mirror x 2 2. Capacity : 110
		Subsidiary space 6.6x8.8 x3	Rehearsal Studio-04 use only GreenRoom-01(With dressing room)
1192	Rehearsal Studio-05	19.3x12.2x3.9	1. Grand Piano, Wooden floor , Black color dance floor, Wall mount glassless mirrors x 2 side, Fixed Ballet barre on the single sided wall mirror x 2 2. Capacity : 110
		Subsidiary space 6.6x8.8 x3	Rehearsal Studio-05 use only Green Room-02(With dressing room)
B1111	Rehearsal Studio-06	87.4x2.3	1. Upright piano, Chair, Music stand, Wooden floor, Sound absorption wall 2. Capacity : 25
B1112	Rehearsal Studio-07	5.2x4.4x2.3	1. Chair, Music stand, Wooden floor, Sound absorption wall 2. Capacity : 10
B1113	Rehearsal Studio-08	7.2x5x2.7	1. Chair , Music stand, Wooden floor, Sound absorption wall 2. Capacity : 15
B1114	Rehearsal Studio-09	5.2x3.7x2.7	1. Chair, Music stand, Wooden floor, Sound absorption wall 2. Capacity : 10
B1115	Rehearsal Studio-10	5.2x4.1x2.7	1. Chair , Music stand, Wooden floor, Sound absorption wall 2. Capacity : 10
B1116	Rehearsal Studio-11	5.2 x 4.1 x 2.7	1. Chair , Music stand, Wooden floor, Sound absorption wall 2. Capacity : 10
B304	Chorus Rehearsal Room	15.9x9.9x8.8	1. Grand Piano, Chair, Ensemble stool, Wooden floor, Sound absorption curtain 2. Capacity : 80
B313	Orchestra Studio	18.7x14.3x7.8	1. Fixed auditorium< 84seats>, Grand Piano, Chair, Ensemble stool, Wooden floor, Sound absorption curtain 2. Capacity : 200

### 4-6-2 Carpentry Shop / Costume Shop / Laundry Room

National Kaohsiung Center for the Arts is equipped with basic production facilities, include Carpentry Shop, Costume Shop, and laundry rooms. Those for hire between four major theatres. The hire fees please refer to the rate tables of National Kaohsiung Center for the Arts.

Room No.	Name	Dimension (Length x Width x Height / m)	Notes
1002	Carpentry Shop	11.9x19.7x3	Basic wood crafts and electrical tools
1165	Costume Shop-01	5.9x10.2x3	Basic facilities for the maintenance of costume; Sewing machine, overlock machine and steam / iron equipment
1181	Costume Shop-02	5.8x11.8x3	
1163	Laundry Room-01	5.8x4.9x3	Washing machine, tumble dryers, sink and clothes folding table
B1019	Laundry Room-02	6x8.2x3	